

RECOMMENDED PCB LAYOUT (TOP VIEW)
(GENERAL TOLERANCES : ± 0.05)

QUALITY SYMBOLS	DRAWN BY	DATE	ACES ELECTRONICS
MAJOR \oplus	Wu, Chu Cheng	23'/04/07	
CRITICAL \otimes	CHECKED BY	DATE	TITLE
GENERAL TOLERANCES (UNLESS SPECIFIED)	Huang, Kuo Hua	23'/04/07	
X ± 0.5	APPROVED BY	DATE	SIZE
X ± 0.25	Huang, Kuo Hua	23'/04/07	A4
.XX ± 0.15	UNITS	mm	REQ NO.
.XXX ± 0.1	SCALE	2 : 1	N/A
ANGLES $\pm 2^\circ$	SHEET NO.	2 OF 5	REV
	DWG NO.	B	52730-XXXXX-XXX

74 POS.

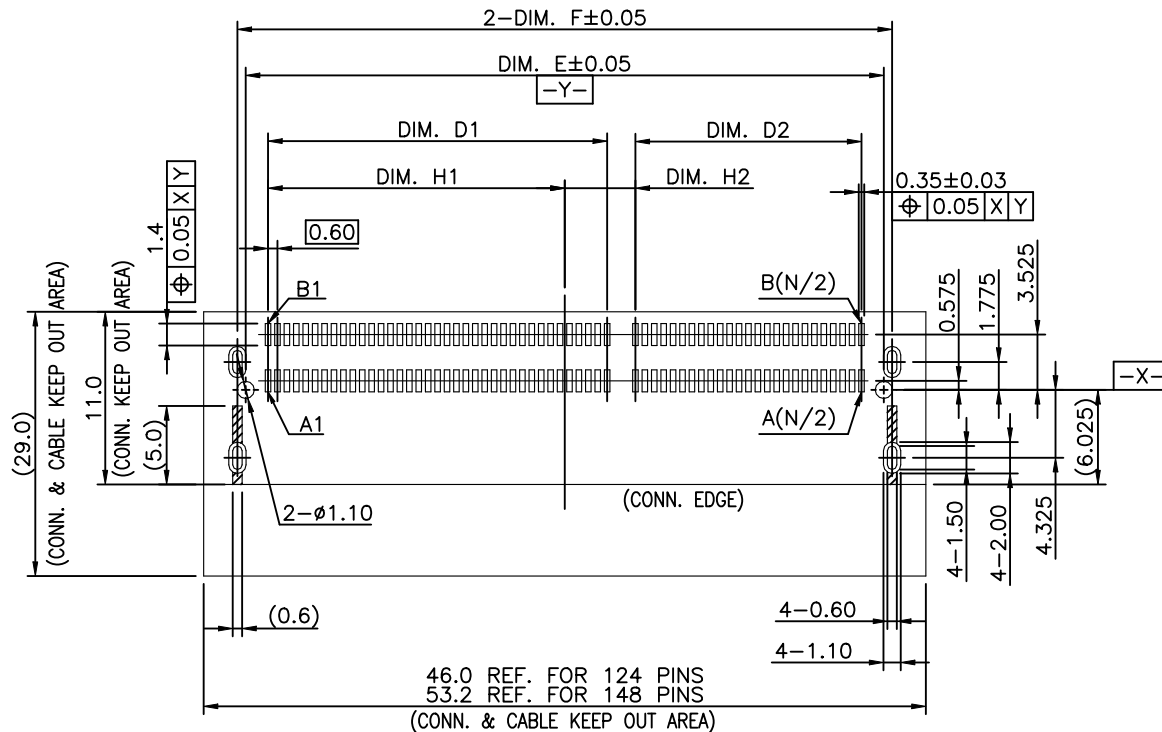
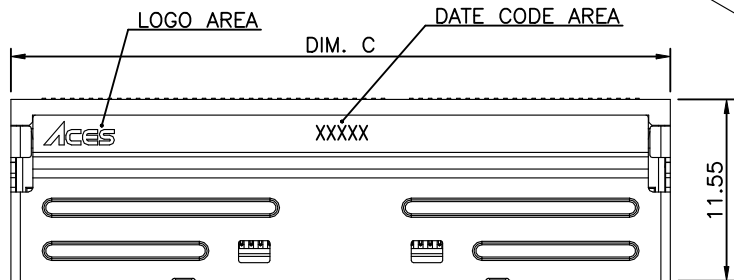
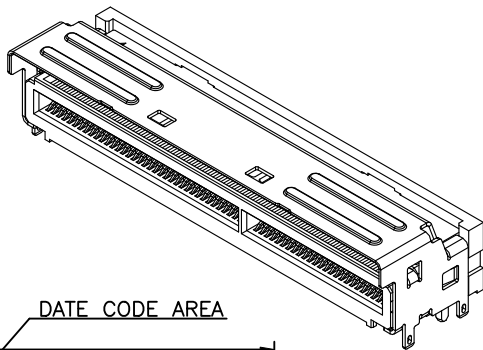

46.0 REF. FOR 124 PINS
53.2 REF. FOR 148 PINS
(CONN. & CABLE KEEP OUT AREA)

RECOMMENDED PCB LAYOUT(TOP VIEW)
(GENERAL TOLERANCES : ±0.05)

☒ SHELL KEEP OUT AREA

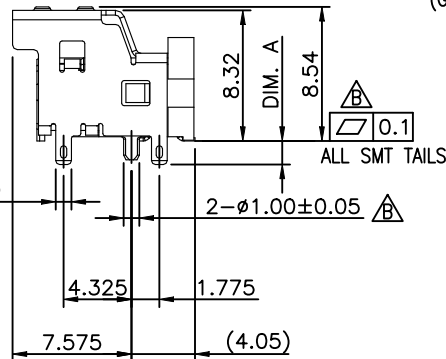
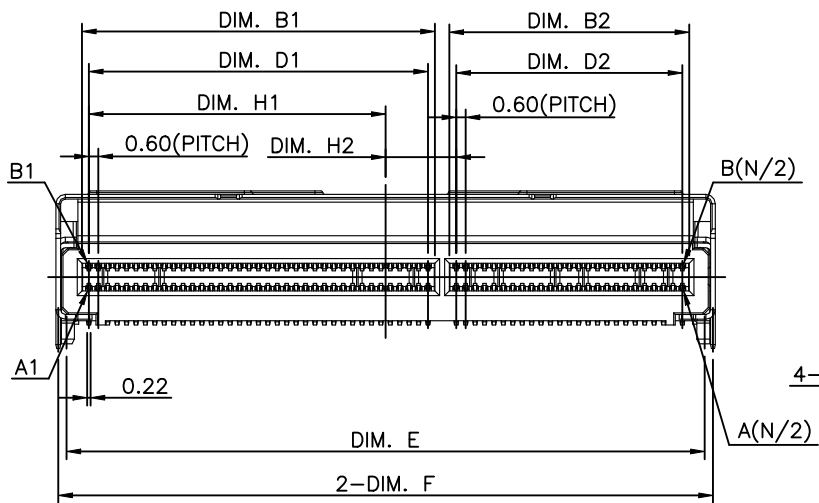

PART NUMBER	CKTS (N)	DIM. B1	DIM. B2	DIM. C	DIM. D1	DIM. D2	DIM. E	DIM. F	DIM. H1	DIM. H2
52730-124XX-XXX	124	22.48	15.28	42.00	21.60	14.40	40.645	41.70	18.90	4.50
52730-148XX-XXX	148	22.48	22.48	49.20	21.60	21.60	47.845	48.90	22.50	0.90

124 & 148 POS.

QUALITY SYMBOLS MAJOR Ⓢ CRITICAL Ⓢ GENERAL TOLERANCES (UNLESS SPECIFIED) X ±0.5 .X ±0.25 .XX ±0.15 .XXX ±0.1 ANGLES ±2°	DRAWN BY Wu, Chu Cheng DATE 23'/04/07		TITLE MINI COOL EDGE IO INTEGRATED CONNECTOR RIGHT ANGLE, 0.6 PITCH FOR PCIE, SMT TYPE
	CHECKED BY Huang, Kuo Hua DATE 23'/04/07		
UNITS mm		SIZE A4	RFPQ NO. N/A
SCALE 2 : 1	SHEET NO. 3 OF 5	REV B	DWG NO. 52730-XXXXX-XXX

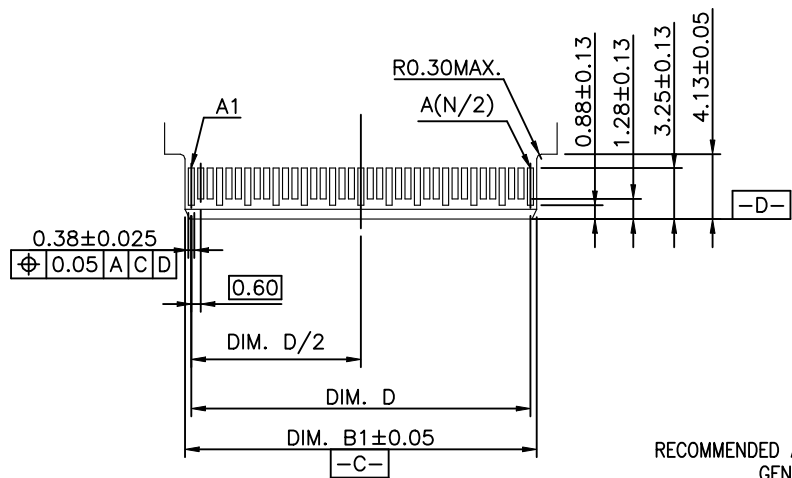

RECOMMENDED AIC MATING CARD DIMENSIONS(1 PORT)
GENERAL TOLERANCES : ±0.05

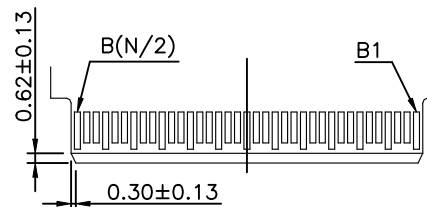

PART NUMBER	CKTS (N)	DIM. B1	DIM. D
52730-038XX-XXX	38	11.60	10.80
52730-050XX-XXX	50	15.20	14.40
52730-074XX-XXX	74	22.40	21.60

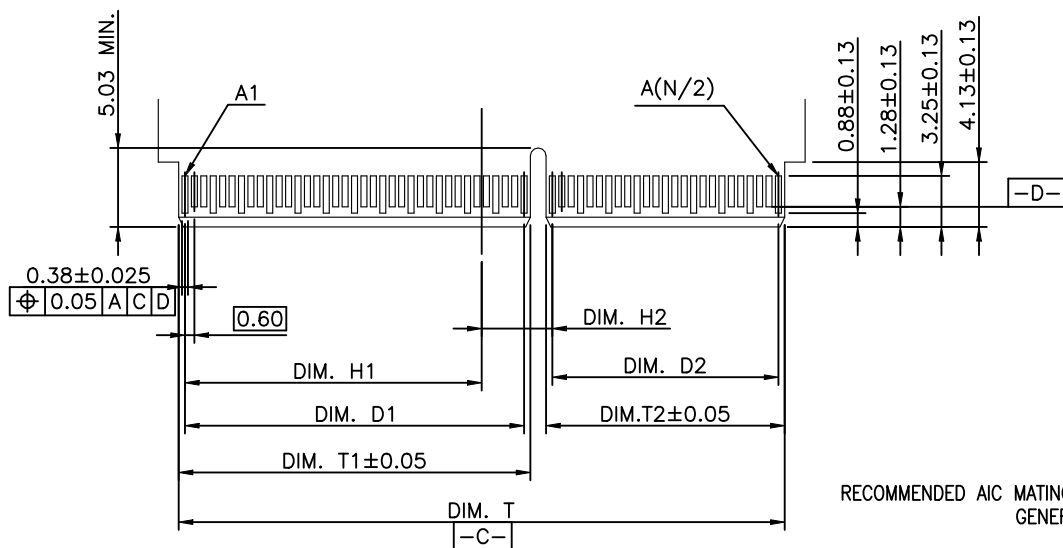
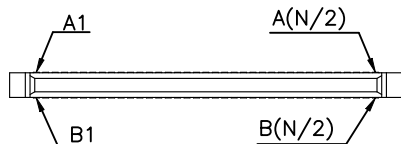

RECOMMENDED AIC MATING CARD DIMENSIONS(2 PORT_124 &148 PIN)
GENERAL TOLERANCES : ±0.05

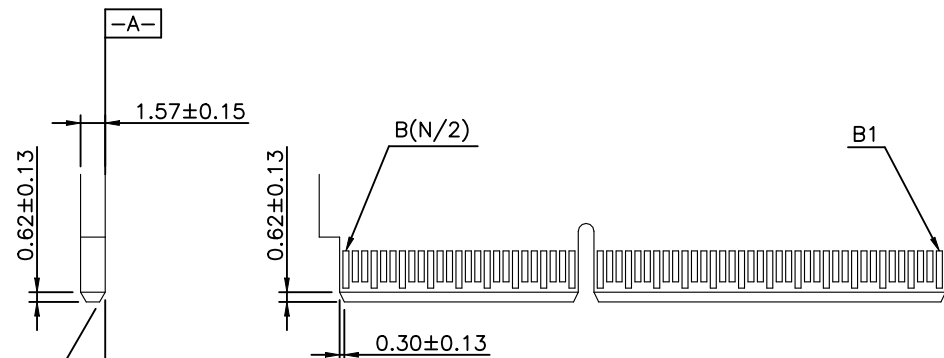

PART NUMBER	CKTS (N)	DIM. D1	DIM. D2	DIM. H1	DIM. H2	DIM. T	DIM. T1	DIM. T2
52730-124XX-XXX	124	21.60	14.40	18.90	4.50	38.60	22.40	15.2
52730-148XX-XXX	148	21.60	21.60	22.50	0.90	45.80	22.40	22.4

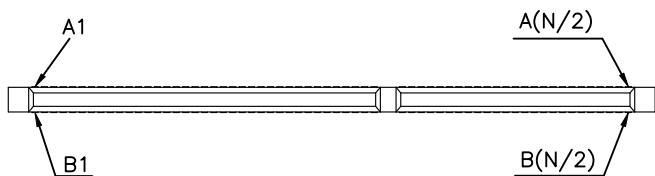

QUALITY SYMBOLS MAJOR Ⓢ CRITICAL Ⓢ GENERAL TOLERANCES (UNLESS SPECIFIED) X ±0.5 .X ±0.25 .XX ±0.15 .XXX ±0.1 ANGLES ±2°	DRAWN BY Wu, Chu Cheng	DATE 23'/04/07	
	CHECKED BY Huang, Kuo Hua	DATE 23'/04/07	
APPROVED BY Huang, Kuo Hua	DATE 23'/04/07	UNITS mm	SIZE A4
SCALE NA	SHEET NO. 4 OF 5	REV B	RFP NO. N/A
		DWG NO. 52730-XXXX-XXX	

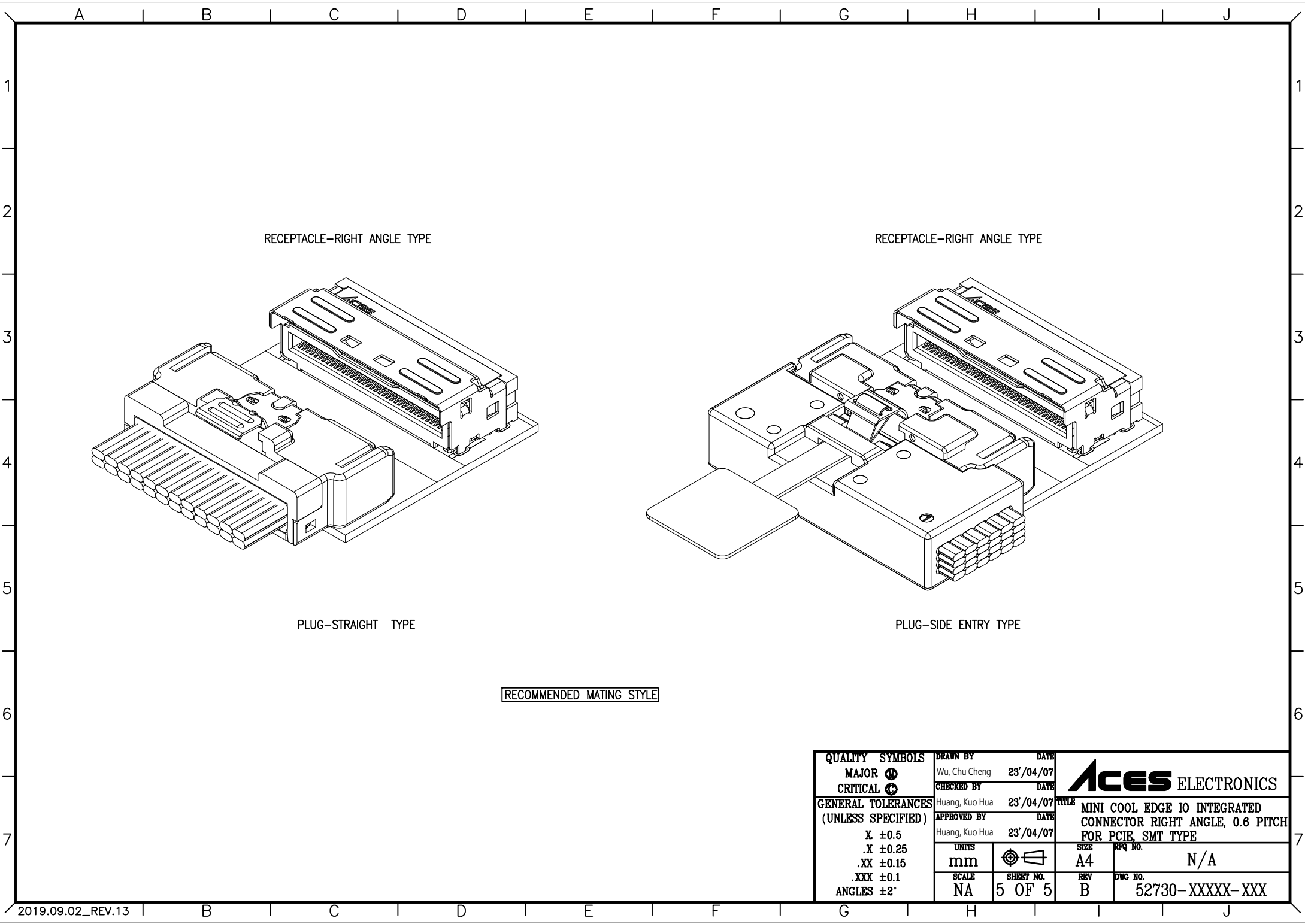

RECEPTACLE-RIGHT ANGLE TYPE

RECEPTACLE-RIGHT ANGLE TYPE

PLUG-STRAIGHT TYPE

PLUG-SIDE ENTRY TYPE

RECOMMENDED MATING STYLE

QUALITY SYMBOLS MAJOR Ⓢ CRITICAL Ⓢ	DRAWN BY Wu, Chu Cheng	DATE 23'/04/07		
	CHECKED BY Huang, Kuo Hua	DATE 23'/04/07		
GENERAL TOLERANCES (UNLESS SPECIFIED)	APPROVED BY Huang, Kuo Hua	DATE 23'/04/07	TITLE MINI COOL EDGE IO INTEGRATED CONNECTOR RIGHT ANGLE, 0.6 PITCH FOR PCIE, SMT TYPE	
	X ±0.5 .X ±0.25 .XX ±0.15 .XXX ±0.1 ANGLES ±2°	UNITS mm		
	SCALE NA	SHEET NO. 5 OF 5	REV B	RFQ NO. N/A
			DWG NO. 52730-XXXXX-XXX	